

A Method for Predicting and Taking Measures Against Soil Slips Generating Debris Flows in a Case Study of the 2014 Hiroshima Sediment Disasters

Yoshiharu ISHIKAWA¹, Hiroyuki UMEZAWA¹, Risa TANABE¹,
Aya TAMEIKE^{1*} and Quoc Dung DANG²

¹ Toa Grout Kogyo Co., Ltd,(2-10-3 Yotsuya Shinjuku-ku TOKYO 160-0004 Japan)

² Dept. of Environmental Technology, Ton Duc Thang University,
(19 Nguyen Huu Tho Street, Tan Phong Ward, District 7, Ho Chi Minh City, Vietnam)

*Corresponding author. E-mail: aya.tameike@toa-g.co.jp

The previous studies indicated that most of debris flows were generated by the soil slips in zero-order channels. If the places of soil slips were predicted accurately before occurrence of them, we could conduct more effective countermeasures against soil slips than usual countermeasures such as check dams for capture the large amount of debris for preventing disasters. The purpose of this study is to propose a method of predicting the places of soil slips and propose the way for preventing occurrence of soil slips or trapping the small amount of debris in the upper reaches of streams. The places of soil slips were examined in case study of the 2014 Hiroshima sediment disasters. The results indicated that about half of soil slips occurred in the zero-order channels and most of soil slips generated debris flows. We proposed that effective measures against the soil slips in zero-order channels to prevent debris flow disasters.

Key words: soil slip, debris flow, zero-order channel, slope stability work, flexible debris flow barrier

1. INTRODUCTION

According to research by *Tsukamoto et al.* [1973], soil slips that cause debris flows are highly likely to occur in zero-order channels. They called all depressions seen on mountainside slopes that have not grown into first-order channels as zero-order channels (under-first-order channels). The zero-order channels are generally defined as terrain whose depth is less than the frontages of depressed contour line groups by using 1/25,000 topographical maps or large-scale topographical maps [*National Institute for Land and Infrastructure Management, Ministry of Land, Infrastructure, Transport and Tourism*, 2016]. *Tsukamoto et al.* [1973] made it clear that soil slips in zero-order channels are widely distributed. However, if one is to predict the causes of debris flows and consider measures to be taken against them, the area of causes of debris flows must be limited because the scope of prediction of points of soil slips is widely distributed, and cost superiority cannot be maintained.

Against such a background, in this paper we have classified the points of soil slips which generate debris flows by geographic feature in consideration

of the August 2014 sediment disasters due to heavy rainfall in Hiroshima Prefecture (Fig.1) with the aim of predicting the generation of debris flows with high probability, and we have calculated the ratio of such occurrences. Then, based on the results thereof, we conducted basic research on a method for predicting



Fig. 1 Study area

and taking measures against generation of debris flows, which we report here. We chose the 2014

Hiroshima disaster as a study area because we could collect a lot of data concerning soil slips and debris flows in a small region and obtain a 1/5,000 contour diagram by using aerial photographs.

Our research covered two geographic areas, namely Mt. Abu (about 585 meters above sea level) and Mt. Takamatsu (about 340 meters above sea level), where debris flows have frequently occurred.

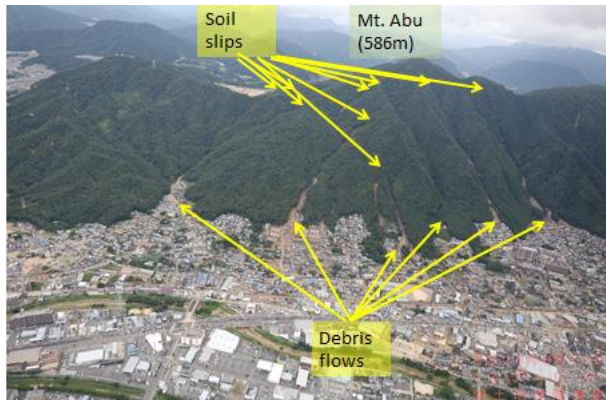

Photo 1 East side of Mt. Abu where many debris flows occurred
(Photo taken by the Geographical Survey Institute, Japan)

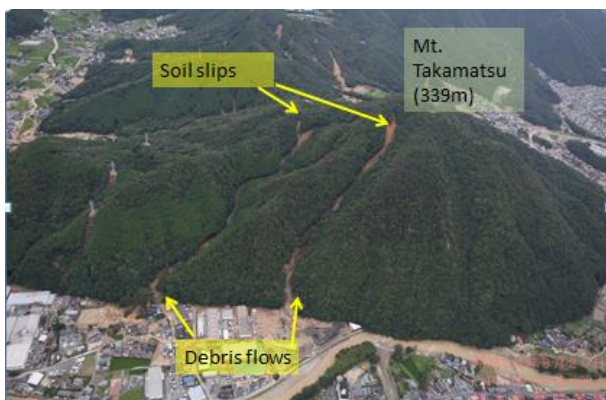

Photo 2 West side of Mt. Takamatsu where many debris flows occurred
(Photo taken by the Geographical Survey Institute, Japan)

2. OUTLINE OF THE SEDIMENT DISASTER IN HIROSHIMA

From 3:00 to 4:00 AM on Aug. 20th, maximum hourly rainfall of 101mm (AMeDAS Miiri Observatory) occurred in the northern part of Hiroshima City, almost at the same time, many soil slips occurred in the headwater of streams around Mt. Abu and Mt. Takamatsu, triggering debris flows (Photo 1,2). The debris flows containing boulders flowed down streams and generated great quantities of sediment and woody debris by eroding the stream bank and stream bed in the middle and upper reaches

[Kaibori *et al.*, 2014]. The debris flows flooded on the alluvial fans and caused great injury with 74 fatalities, and great damage, with 133 totally destroyed houses and 297 houses half and partially destroyed. The areas are geologically made up of weathered granite and sedimentary rock.

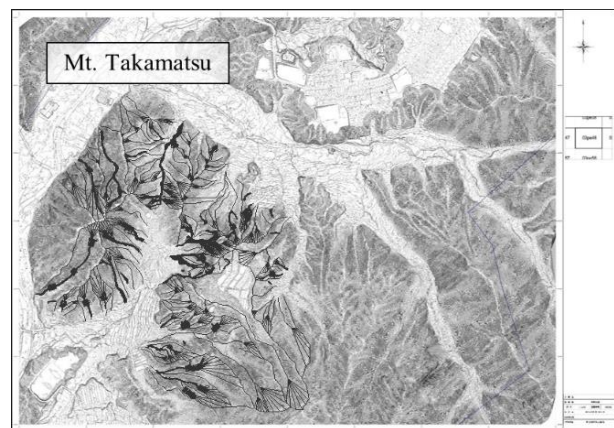
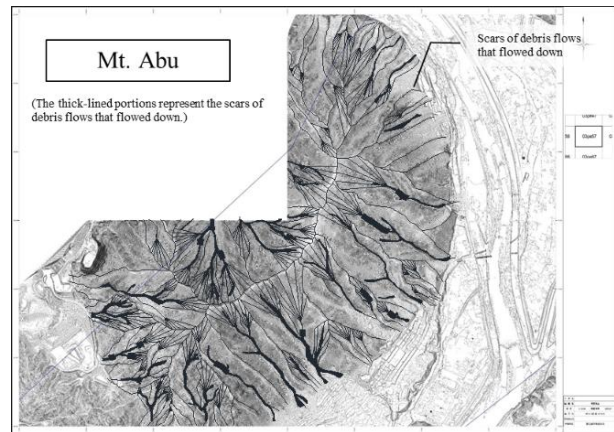

Fig. 2 Reading Conditions of Mt. Abu (top) and Mt. Takamatsu (bottom)
(Provided by Aero Asahi Crop.)

3. METHOD

The scars of the debris flows are shown in a 1/5,000 contour diagram by using aerial photographs taken (by Aero Asahi Crop.) after the occurrence of disasters in the areas covered by our research (Fig 2). In conformity to the set definitions, we classified the points of occurrence of soil slips and calculated the ratios thereof.

Moreover, we classified the soil slips in zero-order channels into three categories to narrow down the areas to predict and then calculated the ratios thereof.

4. DEFINITIONS OF CATEGORIES IN THE OCCURRENCE AREAS

The areas where soil slips were caused in surveyed areas are classified as follows: Category I refers to soil slips in zero-order channels, Category II to bank collapses, and Category III to other soil slips (Fig 3). These definitions are elaborated below.

4.1 Zero-order channels (Category I)

Here, only the upper part of a basin that has grown into a first-order channels is classified as a zero-order channels, which is defined as the areas surrounded by the line of the basin divide and straight lines which

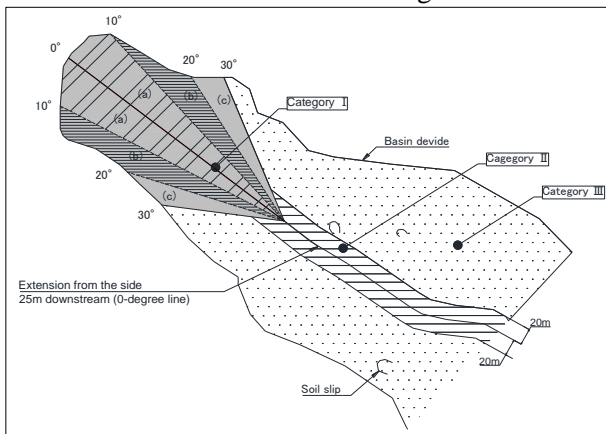

Fig. 3 Soil slip point categories

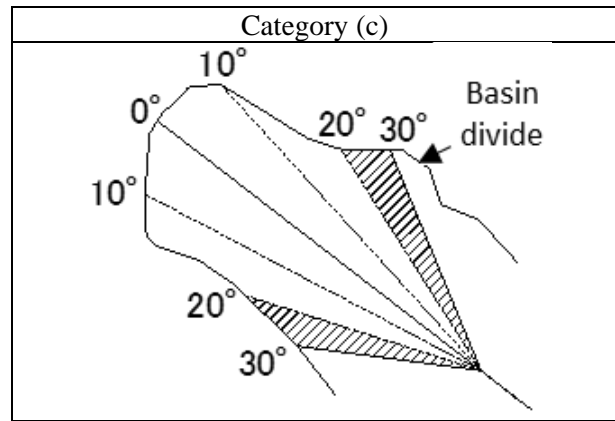

Fig. 4 Zero-order channel categories

each open by 30 degrees toward the right and left bank sides from an extension line that extends from the top end of the first-order channels. The points of soil slips in the areas of a zero-order channels are each divided by 10 degrees from the 0-degree line toward the right and left banks into three equal parts, and they are classified as follows: Category (a) refers to less than 10 degrees, Category (b) to at least 10 but less than 20 degrees, and Category (c) to at least 20 but less than 30 degrees (Fig 4). The areas of soil slips are identified by using aerial photographs and a 1/5,000 contour diagram, then the sizes of areas inside each Category (a), (b), (c) are measured. The Category in which the largest size of area occupies is recognized as the Category for the soil slips.

4.2. Banks (Category II)

Within the areas of a basin divide, the areas surrounded by right and left riverbanks from the trough line within a horizontal distance of 20 meters are classified as banks.

4.3 Others (Category III)

Areas that do not fall under either Category I or II are classified as Category III. These areas are further classified into rising terrain (ridge) or depressed terrain (hollow) based on the terrain of the points of soil slips.

4.4 Debris flows

We define the movements of collapsed materials over 100 meters travel distance as debris flows. Because fluidization of collapsed materials causes long distance travel. Such a movement distance refers to the distance from the source of soil slips to the point where the debris stop; it does not include areas where debris spread out. Also, in the case in which debris flows two or more sources of soil slips join together and flow down, in the same manner, we measure the horizontal distance from each point of

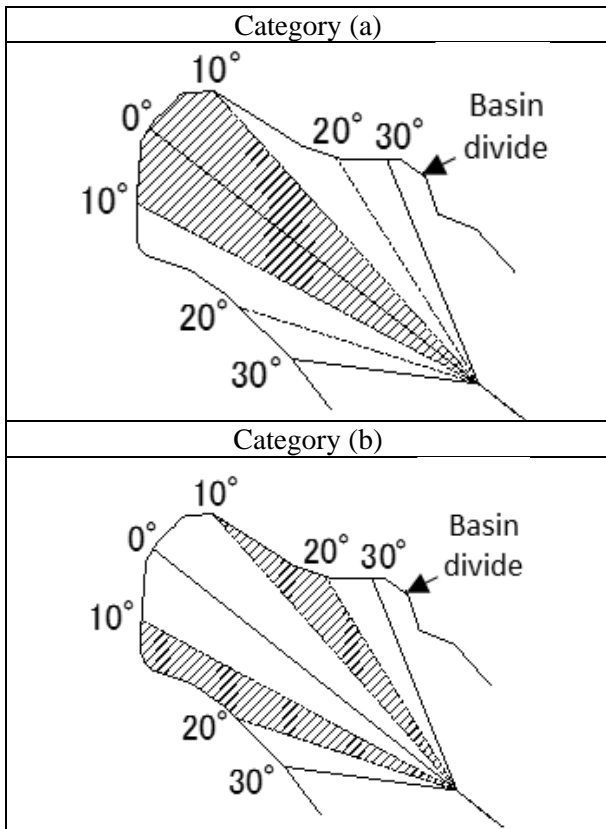

soil slips to the point where the debris stop.

5. RESULTS

5.1 Assessment of points of soil slips

The number of points of soil slips surveyed was 181. According to the classification results, Category had 96 points and the highest rate of occurrence, about 53%. Category II had 18 points and a rate of occurrence of about 10%, while Category III had 67

Table 1 Point of soil slips categories

	Collapsed point categories			
	I . In zero-order channels	II . Banks	III .Others	
			Rising terrain.	Depressed terrain.
Mt.Abu	50	4	2	27
Mt.Takamatsu	46	14	1	37
(1) No of collapsed points	96	18	3	64
			67	
(2) Total No. of collapsed points	181			
(3) Rate of occurrence ((1) / (2)×100)%	53.0	9.9	1.7	35.4
			37.0	

Table 2 Zero-order channels categories

	I . zero-order channels		
	a	b	c
(4) No. of points of soil slips.	43	25	28
(5) Total No.of points of soil slips.	96		
(6) Rate of occurrence ((4) / (5)×100)%	44.8	26.0	29.2

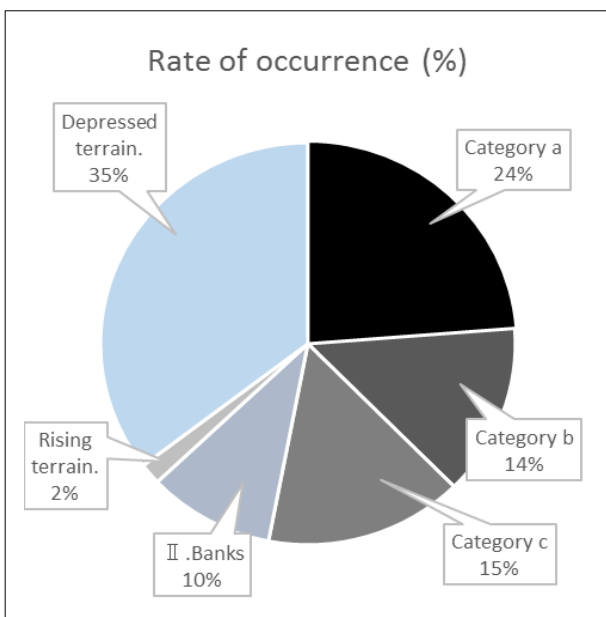

Fig. 5 Rate of occurrence of soil slips

points and a rate of occurrence of about 37%. Of the Category III collapses, 64 points and about 35% occurred in depressed terrain (hollow), showing the second highest rate of occurrence after Category I (Table 1 and Fig.5). Then, we further sub-classified the Category I collapses. Of the 96 points, Category (a) had 43 points and the highest rate of occurrence, about 45%. Category (b) had 25 points and a rate of

Table 3 Total No. of zero-order channels and rate of occurrence

	No. of soil slips in zero-order channels.			No soil slips.
	1 point.	2 points.	3 points.	
(4) No. of zero-order basins with soil slips.	54	15	4	82
	73			
(5) Total No. of zero-order basins among areas interpreted.	155			
(6) Rate of occurrence ((4) / (5)×100)%	74.0	20.5	5.5	52.9
	47.1			

Table 4 Debris flows that moved by category

	Flowed down	stopped
(7) No. of points of soil slips.	156	25
(8) Total No. of points of soil slips.	181	
(9) Flow-down rate ((7) / (8)×100)%	86.2	13.8

Table 5 Debris flows that stopped by category

	I	II	III
(10) No. of debris flow.	90	14	52
(11) Total No. of points of soil slips.	96	18	67
(12) Rate of occurrence(%) ((10) / (11)×100)	93.8	77.8	77.6

occurrence of about 26%, while Category (c) had 28 points and a rate of occurrence of about 29%(Table 2).

Moreover, the number of existing zero-order channels we read in the overall area was 155, and there were 73 points of zero-order channels that had soil slips. Thus, this value accounted for about 47% of all zero-order channels (Table 3).

As to why the rate of occurrence of soil slips increases in depressed terrain in Category I or III, we think that because surface water concentrates in such terrain during times of rainfall, the subsurface water that has concentrated in the surface soil induces soil slips. Therefore, we considered at which point where rainwater from the upper part of the slope concentrates was most likely to soil slips. So, we think that reading such points can contribute to reducing the areas of prediction of points of soil slips.

5.2 Assessment of the flow-down distance of debris flows

We measured the movement distance of debris flows at all 181 points of soil slips. The result indicate that soil slips at 156 points caused debris flows, while at 25 points the soil slips stopped along the way. Thus, we found that about 86% of soil slips that occurred developed into debris flows (Table 4). Nevertheless, regarding the categories of the soil slips that occurred at 25 points where the debris movements stopped along the way, Category I had 6, Category II had 4, and Category III had 15. Thus, we found that the Category II stop along the way is very low (Table 5).

As to why Category I and Category II soil slips developed into debris flows at a high rate, one can point out that there the environment is such that debris can move over a relatively longer distance because of the presence of an area that has grown into a first-order channel, which leads debris directly below or within a horizontal distance of 20 meters. However, regarding the Category I or Category II soil slips that did not develop into debris flows, there are two conceivable patterns, namely soil slips that did not reach first-order channels and soil slips that stopped within first-order channels. Nevertheless, we think it necessary to further consider these by making use of inclination classification drawings and other materials. For reference, in Category III, collapses at 52 points developed into debris flows, and among these, soil slips at 2 points did not flow into first-order channels.

6. PROPOSAL OF MEASURES AGAINST DEBRIS FLOWS

The most debris flows in Hiroshima were generated by soil slips triggered by the heavy rainfall. As for measures preventing occurrence of debris flows, we propose that measures against the soil slips in zero-order channels, namely at the headwater of streams are effective. In the areas surveyed in this research, soil slips occurred in about half of all zero-order channels in the surveyed areas, and most such soil slips developed into debris flows. So, we consider that about half of such debris flows could have been prevented by taking measures against soil slips in zero-order channels. When the debris generated by several soil slips flow together in the middle reaches and the debris flows cause damage in houses or loss of lives in the lower reaches, the measures against soil slips can decrease the volume of harmful debris, even if the generation of debris flows are not completely prevented. As for which

points to take such measures at, we think that the places classified as Category (a) under Category I are important.

When the areas of Category (a) in the areas of zero-order channels with high probability of soil slips are small, slope stability works are suitable for the measures to prevent soil slips which generate debris



Photo 3 An example of slope stability works used by high tensile strength steel net



Photo 4 An example of capture of debris by the flexible debris flow barriers



Photo 5 An example of capture of debris by the flexible debris flow barriers

flows. Since the areas of Category (a) locate in the

headwater of the streams, the construction of measures should be possible by human power and the materials for the measures should be light. Under this construction conditions, the slope stability works used by high tensile strength steel net as shown in Photo 3 are suitable for preventing soil slips and debris flows. The high tensile strength net is manufactured by braiding high tensile strength steel wires in a lattice shape and is fixed on the surface of slope using earth anchors or rock bolts.

Whereas, if the areas of Category (a) are large, flexible debris flow barrier as shown in Photo 4 and 5 which catch the debris generated in the areas of zero-order channels located in the headwater of the streams is suitable for the measures, because when the slope stability works are used, the large scale of structures is necessary. However, in the construction of the flexible debris flow barrier in the headwater of the streams, the transportation materials is small and construction should be conducted in a simple way. The ring net used for the flexible debris flow barrier is manufactured by braiding high tensile steel wires in a ring shape.

Both of the slope stability works and the flexible debris flow barrier used by the high tensile strength steel net have many their record of construction in Japan. Concerning the flexible debris flow barrier, examples of capture of debris are reported as shown in Photo 4 and 5. However, as both the number and area of all zero-order channels are enormous, we think it necessary to determine levels of importance by narrowing down the areas to be surveyed based on which mountain streams have the possibility of causing debris flows as well as the presence or absence of measures for mountain streams and their lower reaches that may stop the debris flows.

Both of the high tensile strength net and the flexible debris flow barriers have their limits of application in size and strength. For example, the strength of anchors which support the wire ropes and

posts have their limits, no matter the tensile strength of steel tension members is very high. Then the flexible debris flow barrier is limited in size and in capture volume. It is not suitable for large size structure.

7. CHALLENGES TO ADDRESS IN THE FUTURE

According to the previous researches on debris flows by *Tsukamoto et al.* [1973] and our researches on the Hiroshima disaster in 2014, most of debris flows were triggered by soil slips in zero-order channels and we proposed the slope stability works used by high tensile strength steel net to prevent occurrence of soil slips and the flexible debris flow barrier to capture the collapsed material and prevent the debris flow from flowing down. However, the geographical features differ place to place and the amount of data which is the basis of our proposal is not sufficient for using it as a general method. We will provide high reliable prediction method for occurrence of soil slips by obtaining many objective data and analyzing those data sorted by every geological feature in various locations in the future.

REFERENCES

- Kaibori, M. et al. (2014): Sediment – related disasters induced by heavy rainfall in Hiroshima City on 20th August, 2014, *Journal of the Japan Society of Erosion Control Engineering*, Vol.67 ,No.4, pp. 49 – 59.
- National Institute for Land and Infrastructure Management, Ministry of Land, Infrastructure, Transport and Tourism, Japan (2016): *Manual of Technical Standards for establishing Sabo master plan for debris flow and driftwood* ,Technical Note of National Institute for Land and Infrastructure Management, No.904, pp.17
- Tsukamoto, Y. et al. (1973): Study on the growth of stream channel (III) — Relationship between 0 (zero) order channels and landslides. *Journal of the Erosion – Control Engineering Society*, Vol.26 ,No.2, pp.14 – 20.